

Current flow follows dashed arrow through the outer body, two split contact rings, tapered tip socket, and to the electrode.

U.S. Pat. No. 3,632,958 Canada Pat. No. 902,189

TUFFALOY fast-follow-up (low inertia) holders solve the problem of maintaining adequate weld pressure on rapidly collapsing projection welds-with fewer set-up problems and reduced maintenance.

These holders can be set to deliver fast-follow-up forces of from 140 to 1300 pounds, a range covering 90% of all projection welding operations. They are compact, water cooled, and easy to maintain.

Plus features of the TUFFALOY fast-follow-up holder include: (1) wider range of pressures than any competitive make (2) no flexible shunt-a common cause of holder failure (3) use of standard, unmodified die springs, so if you need a spring of different strength, it's easily available (4) spring forces available are clearly indicated, so it's easy to set up for a specific force (5) three shank sizes, or it can be platen-mounted-the only fast-follow-up holder that can (6) extremely low height permits use where larger units can't be used.

TUFFALOY fast-follow-up holders can be used to limit the weld pressure of any spot welding machine regardless of cylinder size or air pressure. This is better than reducing air pressure, which slows the return stroke and retards production.

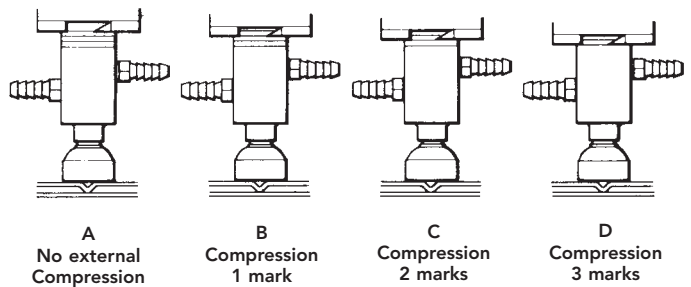
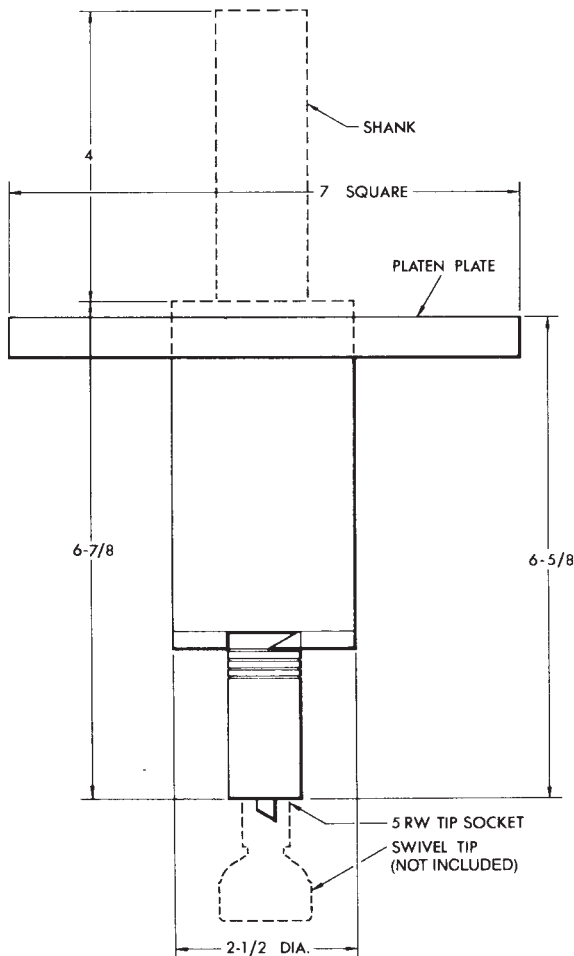

For every one-eighth of an inch that a fast-follow-up is compressed when setting up, a known amount of force is provided, to quickly follow up any reduction in work thickness. Example: at position B, a type MH spring would delivery 310 lb, at C, 440 lb, etc.

FAST-FOLLOW-UP FORCE CHART (LBS.)				
Spring Type	1/8-in. Compression	1/4-in. Compression	3/8-in. Compression	1/2-in. Compression
M (300 lbs. max.)	140	200	250	300
MH (680 lbs. max.)	310	440	560	680
H (1300 lbs. max.)	600	840	1070	1300

Mounting Style	300 LBS. MAX. (M SPRING)		680 LBS. MAX. (MH SPRING)		1300 LBS. MAX. (H SPRING)	
	Description	Part No.	Description	Part No.	Description	Part No.
1" Shank	4620	350-4620	4621	350-4621	4622	350-4622
1-1/4" Shank	4623	350-4623	4624	350-4624	4625	350-4625
1-1/2" Shank	4626	350-4626	4627	350-4627	4628	350-4628
Platen-Mtd.	4629	350-4629	4630	350-4630	4631	350-4631

